

**NEW**

### STANDARD EQUIPMENT

- Automatic outriggers levelling with electronic inclinometer
- Outrigger pads (Ø 200 mm)
- Emergency hand pump
- Cylinder holding valve
- Electronic hour meter
- Load cell
- Hydraulic Jib
- Rubber tracks
- Hydraulically adjustable tracks width
- Double speed traction
- 230V - 16 A electro-pump for indoor use
- Air / Water outlet in the platform
- 230V - 16 A outlet in the platform
- Honda iGX800 petrol engine – 20.1 HP 3600 rpm
- Yanmar 3TNV70 diesel engine – 20.8 HP 3600 rpm
- Removable wired control box (5 m cable)

### OPTIONALS

- 12V emergency electro-pump
- Non-marking rubber tracks
- Oversized outrigger pads (Ø 350 mm)
- Wireless radio-control box
- Working light in the platform
- Aluminium basket (0.90 x 0.75 x 1.10 m)
- Kit IMERVIEW



### BENEFITS

- ✓ Double articulation boom with active jib for a high operability in all construction site conditions.
- ✓ Double stabilization area for greater flexibility of use in various work situations.
- ✓ Hydraulically adjustable tracks width: more stability and traction to move around the building site or rough terrain.
- ✓ State-of-the-art removable control panel: fast and versatile use of the machine.
- ✓ Proportional and simultaneous electro-hydraulic controls: efficiency and safety for operators.
- ✓ Automatic outriggers levelling: maximum easiness of use and safety.
- ✓ Permanent weight control device for improved safety and performance.
- ✓ Slewing 360° (not continuous): outstanding aerial accessibility in any work situation.
- ✓ Basket rotation ± 62°: complete placement on working site in any condition.
- ✓ Compact size, with limited overall outrigger footprint.
- ✓ Engine guarded for safety and working protection.
- ✓ Aluminium basket 1.40 x 0.75 x 1.10 m.
- ✓ Innovative design with fully enclosed structure.

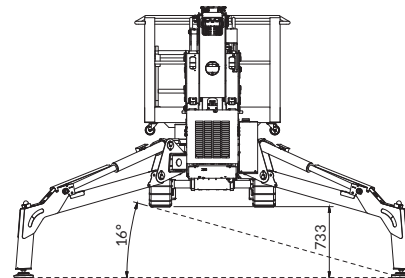
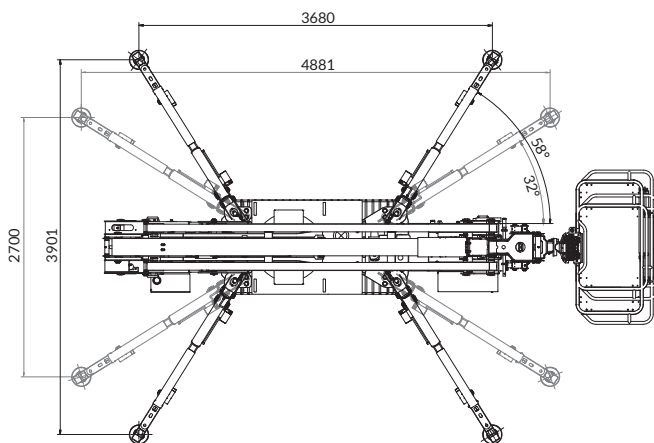
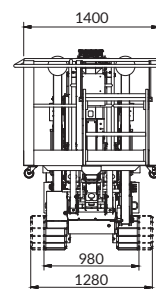
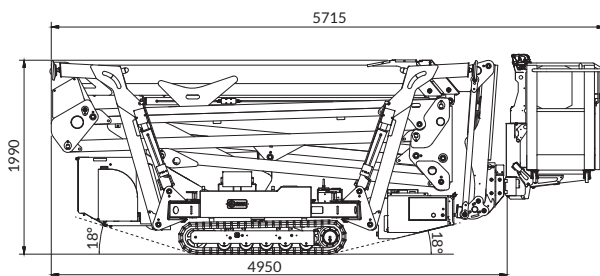
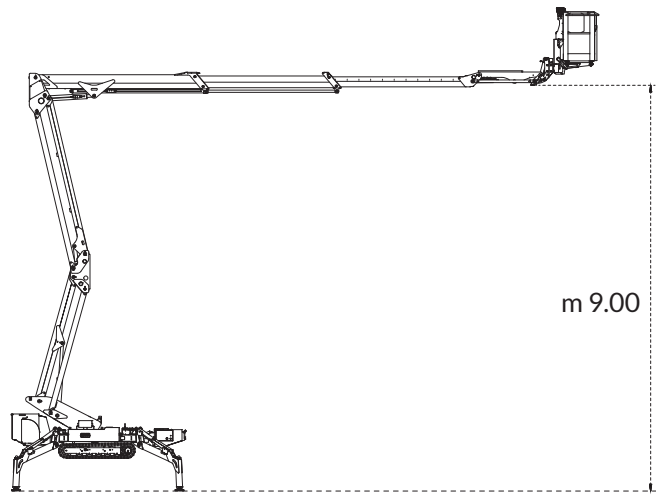

### IMR 23 DA

Working height	m	22.85
Platform height	m	20.85
Side outreach with standard stabilized area	m/kg	10.6 / 230 12 / 140
Side outreach with narrow stabilized area	m/kg	7.3 / 230 8.6 / 140
Up & Over	m	9
Slewing (not continuous)	(°)	360 (180+180)
Basket dimensions	m	1.40 x 0.75 x 1.10
Overall outrigger footprint standard (narrow)	m	3.9 x 3.7 (2.7 x 4.9)
Max driving speed	km/h	2.8
Gradeability	(°)	18
Max load capacity	kg	230
Single-phase electric motor	V / kW	220 / 2.2
Honda iGX800 petrol engine	HP / rpm	20.1 / 3600
Yanmar 3TNV70 diesel engine	HP / rpm	20.8 / 3600
Transport length (without basket)	m	5.70 (4.95)
Transport width (with extended tracks)	m	0.98 (1.28)
Stowed height	m	1.99
Total weight of the machine	kg	2960 (petrol) 3000 (diesel)

