



10.33C

BACKHOE LOADER 4 WHEEL STEERING



- › Max power 106 CV
- › Bucket capacity 1.2 - 1.5 m³
- › Max digging depth 4.80 m (5.80 m)
- › Max permissible weight 9400 kg
- › Hydrostatic transmission
- › 4 wheel drive
- › Stage IIIB / Tier 4i Engine

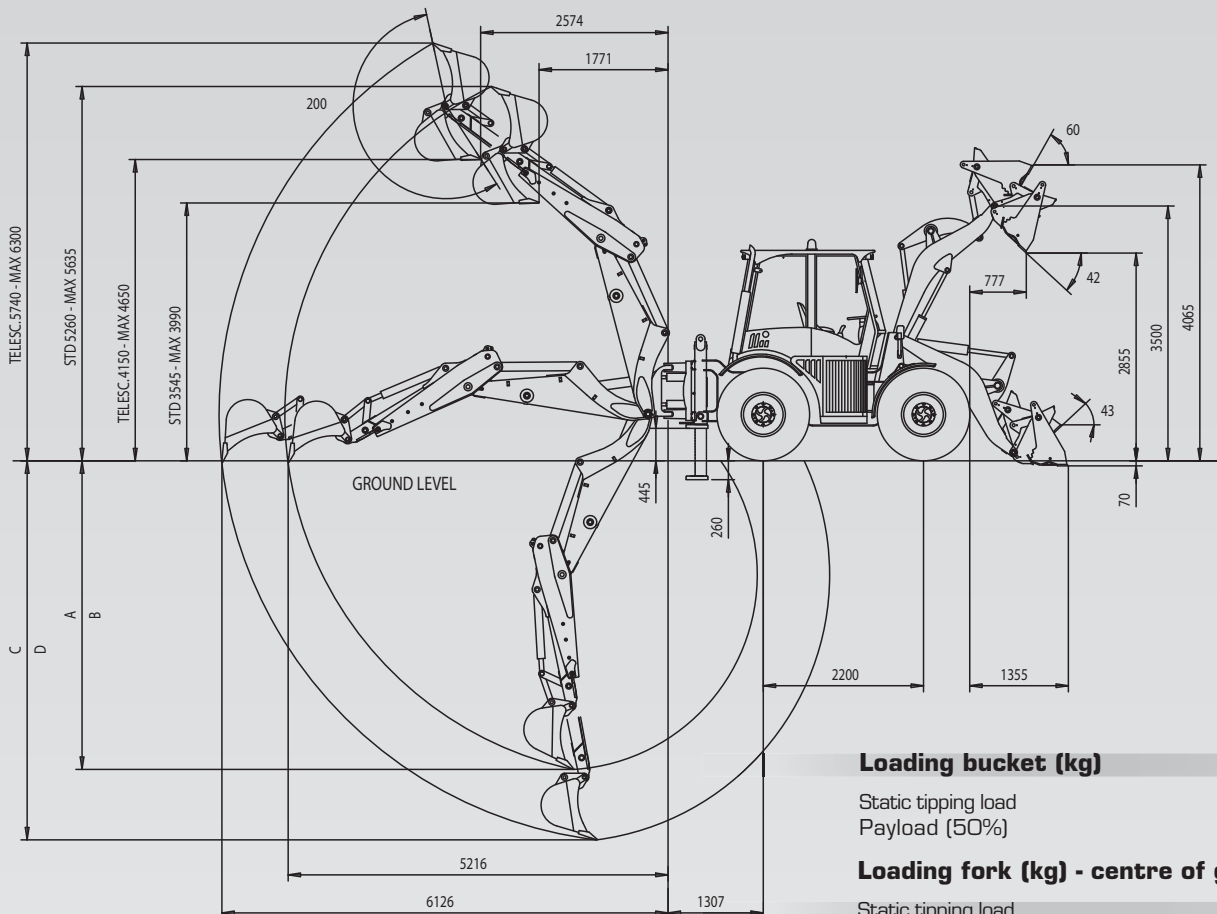
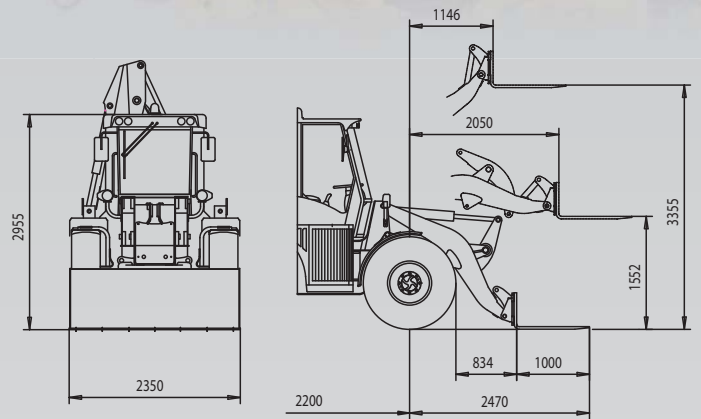
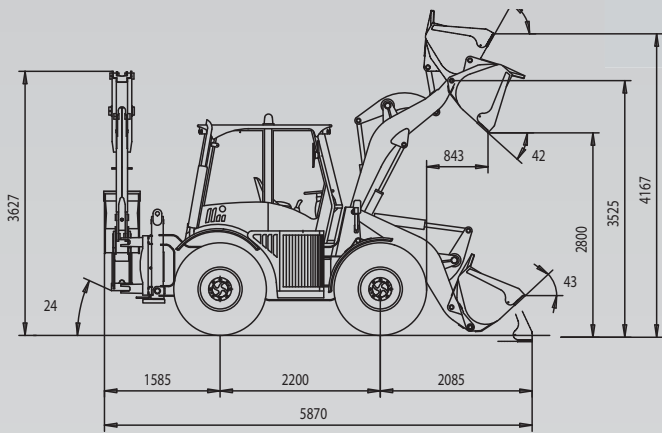

Loading bucket (kg)

Static tipping load	5.600
Payload (50%)	2.800

Loading fork (kg) - centre of gravity 500 mm

Static tipping load	4.600
Payload EN 474-3 (80%)	3.700
Payload EN 474-3 (60%)	2.700
Payload DIN 24094 (50%)	2.300

DIESEL ENGINE

Engine: 4-cylinder in-line, turbocharged, charge air cooling, common Rail injection system electronically controlled, external exhaust gas recirculation, water cooled, dry filtration, oxidation catalyst (DOC) Emissioned according to CEE 97/68 Stage IIIB/Tier 4i.

Type	Deutz TCD 3.6 L4
Max power	78 kW - 106 CV
Rated rpm	2.300
Power ISO/TR 14396	74,4 kW - 101 CV
Power EEC 80/1269	74,4 kW - 101 CV
Max torque	410 Nm
Bore	mm 98
Stroke	mm 120
Displacement	cm ³ 3.620

ELECTRIC SYSTEM

Battery	12 Volt
Capacity EN 60095-1	110 Ah - 1100 A
Alternator rating	95 A
Reverse warning	Standard
Wiring according with	IP 67 DIN 40050

TRANSMISSION

Hydrostatic transmission with automatic power regulation and closed circuit with variable displacement pump and motor. Gear-box with 2 mechanical selections: 2 work speeds (fwd/rev) and 2 road speeds (fwd/rev).

Work speed	forward	reverse
1 st gear km/h	0÷6	0÷6
2 st gear km/h	0÷13	0÷13

Road speed		
1 st gear km/h	0÷18	0÷18
2 st gear km/h	0÷40	0÷40

AXLES

Designed for Heavy Duty.
All-wheel drive.
Planetary final drives in each wheel.
Front axle: steering and oscillating up to a total angle of 20°
Rear axle: steering and fixed to the frame

BRAKE SYSTEM

Service: multi-disc oil brakes on all wheels.
Parking: mechanical brake operating on the service brake, manually actuated.

TYRES

Standard	405/70 R 24
Option	15.5 R25 • 17.5 L 24

STEERING

Servo-assisted through hydraulic steering with the following system:

- on front wheels for road transport
- on each wheel inside the working site, where the maximum maneuverability in reduced spaces is required.
- on each wheel for crab steering inside the working site for side displacement.

Inner tyres turning radius	mm 2.570
Outer tyres turning radius	mm 3.335
Outer bucket turning radius	mm 5.600

HYDRAULIC SYSTEM

Composed of two gear pumps, the first for the loader circuit and steering, the second for the circuit of the fan, having a double speed of rotation. Modular two-element control valve for the loader, modular six-element control valve for the backhoe.

Double acting hydraulic cylinder.
Hydraulic oil cooling radiator.
Full-flow oil filter on the leakage pipe.

Max flow	lt/1'	130
Loader relief valve pressure	bar	210
Steering relief valve pressure	bar	175
Lift cylinder	mm	90x665
Bucket cylinder	mm	110x445

Loader control

Single lever arm-control with 4-position lifting system and with 3-position bucket system.

Backhoe control

Two levers backhoe control, "cloche" type.
Two hydraulic-control independent stabilizers.
Side translation with four hydraulic locking devices.

SERVICE CAPACITIES

Engine	lt	8
Front axle	lt	10,8
Rear axle	lt	10,8
Gear box	lt	1,6
Hydraulic circuit	lt	110
Brake system	lt	0,9
Fuel	lt	110
Water cooling	lt	24

TECHNICAL FEATURES

Loader

Standard bucket capacity	m ³	1,20
Bucket width	mm	2.350
Breakout force	kg	9.100

Backhoe loader

Type	VF	4.45C
Standard bucket capacity	lt	160
Bucket width	mm	500
Dipperstick max penetration capacity	kg	4.450
Max breakout force on the bucket tip	kg	5.550
Lifting capacity on the bucket pin up to max height	kg	1.500
Rotating		180°
A - Max digging depth	mm	4.800
B - Standard digging depth	mm	4.400
C - Max digging depth with telescopic (opt.)	mm	5.800
D - Standard digging depth with telescopic (opt.)	mm	5.400

DIMENSIONS AND WEIGHT

Max length in transfer position	mm	6.000
Max width in transfer position	mm	2.350
Width across tyre	mm	2.290
Tracks width	mm	1.890
Ground clearance	mm	450
Standard weight in running order	kg	8.200
Max permissible weight	kg	9.400



Via Piratello, 106 - 48022 Lugo (RA) ITALY
Tel. +39 0545 904411 Fax +39 0545 30389
e-mail: info@vf-venieri.com www.vf-venieri.com
Spare Parts
Tel. +39 0545 904429 Fax +39 0545 24555